

# BlueClean<sup>®</sup> HC PRO Lite



**integratedAIR<sup>®</sup>**  
FILTRATION

[www.integratedairfiltration.co.uk](http://www.integratedairfiltration.co.uk)

# BlueClean® HC PRO Lite

Our BlueClean® HC PRO Lite is designed as a compact and cost-effective solution to your dust and fume extraction needs which can be supplied as a true 'plug and play' filter unit. All key elements of the unit are integral; therefore easy to install and commission. The HC PRO Lite can house between 2 and 8 filter elements. This range is suitable for a wide range of dry dust process requirements.

**Robust construction**

**True downflow cleaning technology**

**Tool less filter cartridge change**

**ATEX certified for PRO Lite E**

**Design ranges from 2 to 8 cartridges**

**Integrated fan design**

**Cost-effective solution**

**Safe to use with explosive dusts**

**Reduced footprint to optimise production area**

**Low maintenance**

**Longevity of cartridge filters**

**Adaptable to each unique requirement**

**Plug and Play unit** - for easy installation and commissioning.

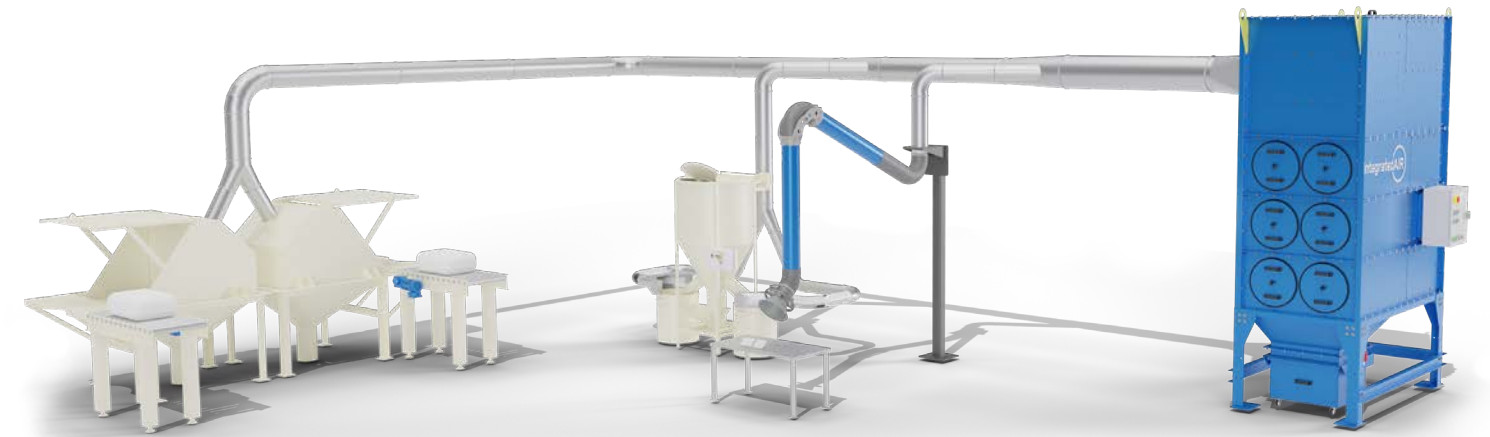

The sectors that we typically supply to - but not limited



## Options

- Various inlet positions available
- Multiple inlet types available including ductwork adapters and anti-abrasion inlets
- Wide range of filtration medias available including spun bond polyester, anti-static spun bond polyester, cellulose nanoweb, PTFE coated and membrane medias
- Multiple waste collection/discharge methods available including bin collection, 45 gallon drum, rotary valve discharge, etc.
- Our units can be powder coated in any RAL colour and finish (eg: textured, semi-gloss, full gloss, etc) and to any specification (eg: C4M coastal)
- Filter safe change design available
- Secondary HEPA filtration
- Choice of pulse sequence control panels available including two DP (differential pressure) cleaning panels that include a 4-20mA outfeed facility for setting alarm conditions and external monitoring



## BlueClean® HC PRO Lite

---

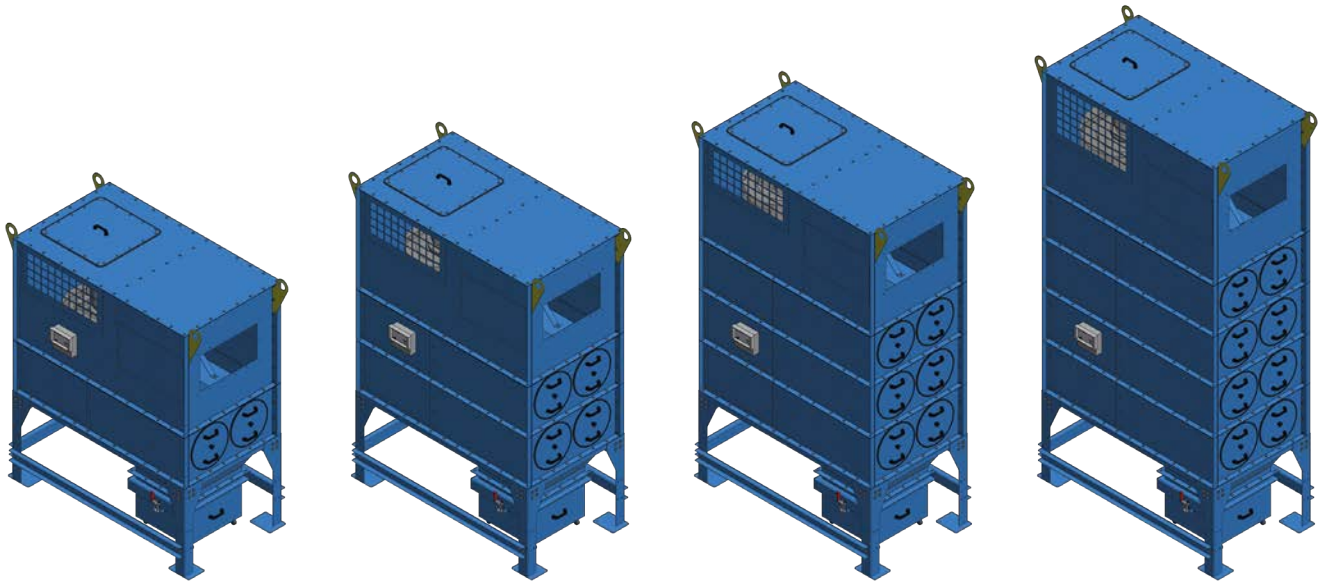

## BlueClean® HC PRO Lite E

---

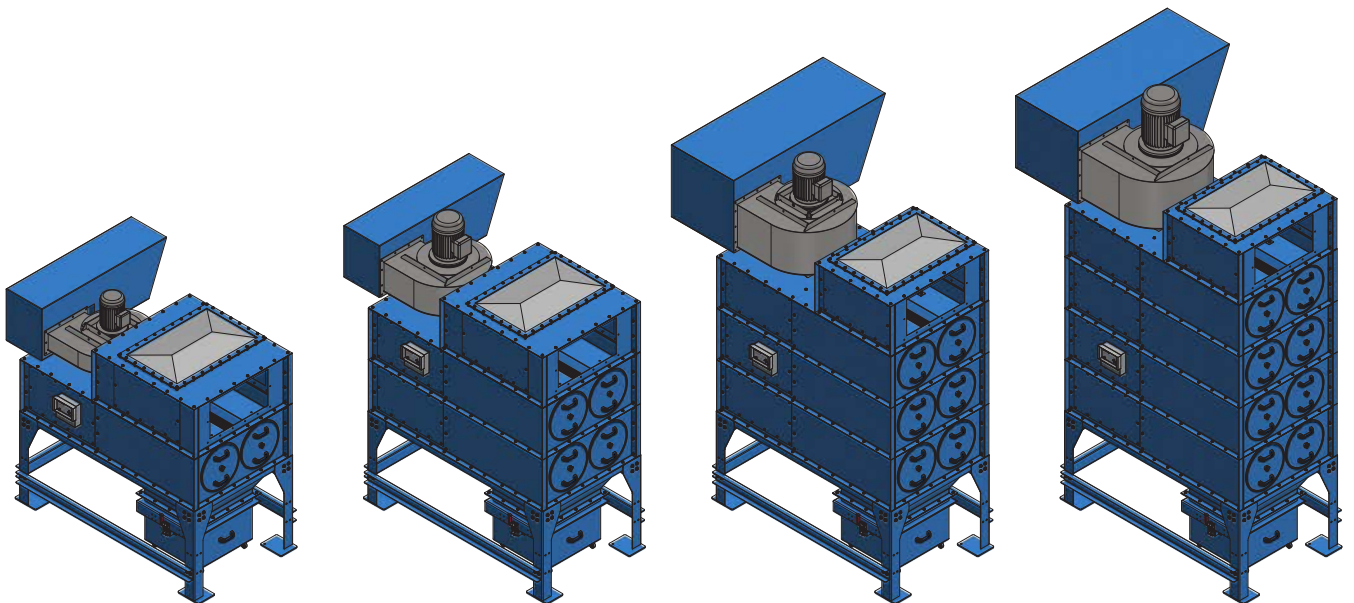

[www.integratedairfiltration.co.uk](http://www.integratedairfiltration.co.uk)

t +44 (0) 113 518 5939 sales@integratedairfiltration.co.uk

Unit 28 Pullan Way | Howley Business Village | Morley | Leeds LS27 0BZ | United Kingdom

